



“Conventional Zone” – for AGBQ Models

The Conventional Zone allows the griller to cook at lower temperatures for slower cooking than can be achieved by the Infrared Burner. When the two burners are used together, you have the widest range of temperatures available in a gas grill.

Parts List:

1 – SOL- CZ** (Varies by Model) Stainless Steel U-Burner & Stainless Steel Flavorizing Tray

Installing the Conventional Zone Burner Assembly.

1. Remove the Cooking Grid, Infrared Burner and Screen. Store the Infrared Burner in a moisture-free place, safe from the possibility on impact damage, so that it will be in good condition for future use.
2. Remove the retaining screw from the existing Igniter Electrode, put the screw to one side for re-use.
3. Remove the front Control Knobs for adjustment to low flame setting.
4. Slide existing Igniter Electrode to lower position and refit existing retaining screw.

INFRARED BURNER REMOVAL

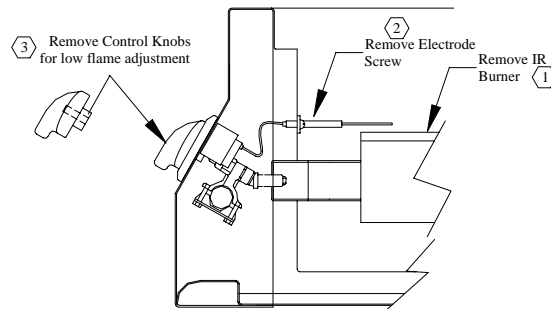

CONVECTION BURNER INSTALLATION

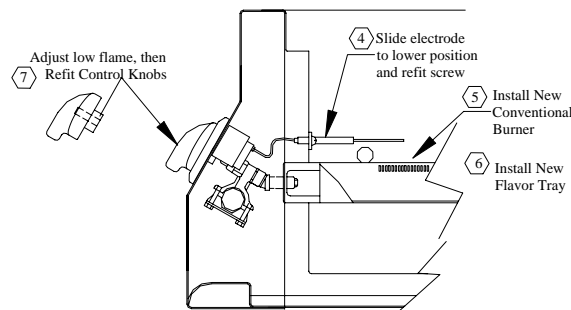

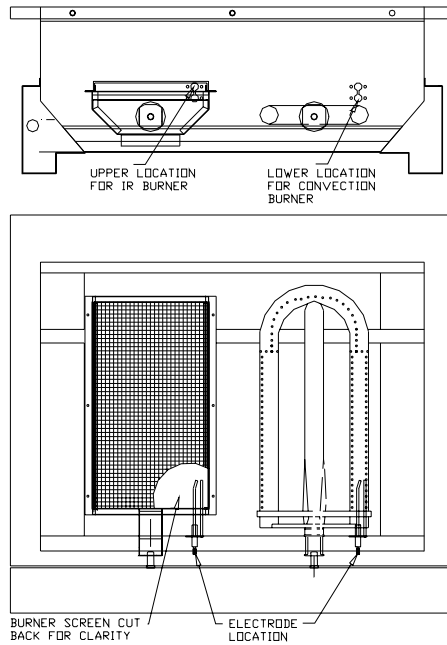

5. Install the New “U” shaped burner by passing the front end through the firebox front and correctly positioning over the Control Valve orifice, and the rear bracket sitting onto the burner hanger.
6. Install the stainless steel Vaporizing tray onto the four (4) studs protruding from the firebox front and rear panels.
7. Adjust the low flame setting per the instructions in you Care & Use Manual.
8. Re fit the Cooking Grid in position over the Vaporizing tray.

CONVECTION BURNER INSTALLATION

1. FLAVOR TRAY (1)
2. CONVECTION BURNER (1)
3. GRILL HEAD (existing)
4. COOKING GRIDS (2 existing)

